

EAST BETHEL PERMITS  
 2241 221 AVE NE  
 EAST BETHEL MN 55011  
 763-367-7844  
 763-434-9578 (FAX)



CITY OF EAST BETHEL  
 PUBLIC RIGHT-OF-WAY  
 APPLICATION

Permit # _____ <b>Fee: \$300.00</b>
--

- OBSTRUCTION PERMIT  
 EXCAVATION PERMIT

GSOC Registration #:		Plan #		Project #	
Location (Street Address; Street Intersection):					
Applicant:		24 Hour Phone #:		E-mail Address:	
Address:		City		State Zip	
Contact Person		Work Phone #:		24 Hour #:	
Cell Phone#		Pager #:			
General Contractor:				GSOC Registration #:	
				24 Hour #:	
Contact Person:		Work Phone #:		Home Phone #:	
Sub Contractor #2:				GSOC Registration #:	
<input type="checkbox"/>	Cable TV	<input type="checkbox"/>	Cooling	<input type="checkbox"/>	Traffic
<input type="checkbox"/>	Gas:	<input type="checkbox"/>	High Pressure	<input type="checkbox"/>	Low Pressure
<input type="checkbox"/>	Electrical, Voltage:	<input type="checkbox"/>		<input type="checkbox"/>	Sewer
<input type="checkbox"/>	Telecomm:	<input type="checkbox"/>	Fiber	<input type="checkbox"/>	Other:
Conduit (Size & Kind):					
Cable (Size & Kind):					
<input type="checkbox"/>	New	<input type="checkbox"/>	Replacement	<input type="checkbox"/>	Repair
<input type="checkbox"/>		<input type="checkbox"/>		<input type="checkbox"/>	Other:
<input type="checkbox"/>	Trench	<input type="checkbox"/>	Hole	<input type="checkbox"/>	Chamber
<input type="checkbox"/>	Aerial	<input type="checkbox"/>	Plow (Specify)	<input type="checkbox"/>	Other:
Excavation Size:		Length:		Width:	
ROW being used:		Driving Lane		Parking Lane	
Type of Material:		Concrete		Bituminous	
Structures:		Curb & Gutter		Sidewalk	
Shoulders:		Bituminous		Gravel	
Estimated Starting Date:			Weekend Dates:		
Estimated Ending Date:			After Hours Dates:		

The undersigned herewith accepts the terms and conditions of this permit by the City of East Bethel as herein contained and agrees to fully comply therewith to the satisfaction of the City of East Bethel. The undersigned also declares that he/she has read, understands, and will comply with all relevant City Ordinances and all Right of Way Regulations.

**Applicants Signature:** \_\_\_\_\_ **Date:** \_\_\_\_\_

It is expressly understood that this permit is conditioned upon replacement or restoration of the roadway to its original or to a satisfactory condition. It is further understood that this permit is issued subject to the approval of local city, village, or borough authorities having joint supervision over said street or highway and subject to the applicant's compliance with the rules and regulations of the Minnesota Environmental Quality Council and any other affected government agencies. **All legal requirements listed under "Special Provisions" to be complied with. The date when work is completed must be reported to the City of East Bethel Permits Department for final inspection.**

Approved: \_\_\_\_\_ Authorized Signature \_\_\_\_\_ Date: \_\_\_\_\_

CITY OF EAST BETHEL SPECIAL PROVISIONS FOR INSTALLATION OF UTILITIES OR  
UNDERGROUND CONSTRUCTION AND STREET EXCAVATION  
WITHIN PUBLIC RIGHT OF WAY

1. No work under this application is to be started until application is approved and the permit is issued.
2. Notify Police, Fire, and Street Department at least 24 hours in advance prior to construction or street closing, including all utility companies, public and private, except in the case of emergencies when notification shall be prior to evacuation. One copy of the permit and the special provisions must be available at the site. A \$500.00 fine will be imposed if you or your subcontractor fails to give prior notification.
3. Where work on traveled roadway is necessary, traffic must be protected, and flags, flares and proper barricades must be placed in accordance with the standards of the Minnesota Department of Highways
  - a. If it is not possible to allow traffic to pass, a suitable detour must be provided.
  - b. Barricades are to be erected in a manner, which will provide suitable visibility in all directions.
4. Excavations must be cribbed when necessary depending on type of soil in order to prevent cave-ins.
  - a. No undermining of streets, curbs, bituminous trails, and/or sidewalks (except for boring) will be allowed. **When at all possible excavation holes must be a minimum of 3 feet away from any pavement.**
5. Underground construction must be so constructed as not to harm or unnecessarily destroy the root growth of adjacent or ornamental trees.
6. Turf, sodded area will be sodded and other areas can be seeded. It is the permit holder's responsibility to maintain sod/seed. 4" of topsoil is required.
7. No trenching across surfaced roadways, unless it can be demonstrated to the city engineer that no reasonable alternative exists.
8. **All back filling must be placed in 6-inch layers and thoroughly tamped**, unless otherwise directed and material must be flush and even with the road surface when finally in place. No rock, unstable soil, or bituminous material shall be returned to the back-filled trench.
9. Finished surface, base, and sub-base, of road after excavation and back-fill, shall be at least equal in stability to finished surface, base, and sub-base prior to excavation. A minimum 6" class 5 gravel base material shall be placed at the upper surface of the excavated trench unless otherwise directed.
10. Bituminous and concrete placement shall be replaced according to specifications.
11. If settlement occurs or excavation caves in within one year from completion date so that replaced materials settle (bituminous mat or concrete base), it shall be restored to its original condition by the holder of this permit.
12. No pole anchors, anchors, braces, or other construction shall be placed on roadway shoulder except by special authorization.
13. No driving onto highway from ditch or driving on shoulders except when noted in application for permit.
14. No machine excavations shall be permitted except when noted in application for permit.
15. In compliance with OSHA standards, excavations greater than four feet in width at top of trench will not be generally permitted, and may be made only when expressly provided for on the permit.
16. Streets may not be closed to traffic unless expressly authorized by the permit and necessary notifications have been made.
17. No lugs shall be used on equipment traversing roadways, which will damage the road surface.
18. Roadside and/or site shall be cleaned up after work is completed. **Any disturbed areas will be restored to existing conditions or better.**
19. Within 24 hours, and during normal working hours, (no permits for any type of excavation on public property will be issued for construction on Saturday, Sunday or legal holidays, except for emergency repairs) the permit holder shall notify the City Permits Department issuing the permit and, when applicable, the county engineer, that such work has been completed and is ready for final inspection.
20. No street excavation shall be allowed between November 15<sup>th</sup> and May 15<sup>th</sup>, except for emergencies.

# APPENDIX D

## FIRE APPARATUS ACCESS ROADS

*The provisions contained in this appendix are not mandatory unless specifically referenced in the adopting ordinance.*

### SECTION D101 GENERAL

**D101.1 Scope.** Fire apparatus access roads shall be in accordance with this appendix and all other applicable requirements of the *International Fire Code*.

### SECTION D102 REQUIRED ACCESS

**D102.1 Access and loading.** Facilities, buildings or portions of buildings hereafter constructed shall be accessible to fire department apparatus by way of an approved fire apparatus access road with an asphalt, concrete or other approved driving surface capable of supporting the imposed load of fire apparatus weighing at least 75,000 pounds (34 050 kg).

### SECTION D103 MINIMUM SPECIFICATIONS

**D103.1 Access road width with a hydrant.** Where a fire hydrant is located on a fire apparatus access road, the minimum road width shall be 26 feet (7925 mm). See Figure D103.1.

**D103.2 Grade.** Fire apparatus access roads shall not exceed 10 percent in grade.

**Exception:** Grades steeper than 10 percent as approved by the fire chief.

**D103.3 Turning radius.** The minimum turning radius shall be determined by the fire code official.

**D103.4 Dead ends.** Dead-end fire apparatus access roads in excess of 150 feet (45 720 mm) shall be provided with width and turnaround provisions in accordance with Table D103.4.

**TABLE D103.4  
REQUIREMENTS FOR DEAD-END FIRE  
APPARATUS ACCESS ROADS**

LENGTH (feet)	WIDTH (feet)	TURNAROUNDS REQUIRED
0-150	20	None required
151-500	20	120-foot Hammerhead, 60-foot "Y" or 96-foot-diameter cul-de-sac in accordance with Figure D103.1
501-750	26	120-foot Hammerhead, 60-foot "Y" or 96-foot-diameter cul-de-sac in accordance with Figure D103.1
Over 750	Special approval required	

For SI: 1 foot = 304.8 mm.

**D103.5 Fire apparatus access road gates.** Gates securing the fire apparatus access roads shall comply with all of the following criteria:

1. The minimum gate width shall be 20 feet (6096 mm).

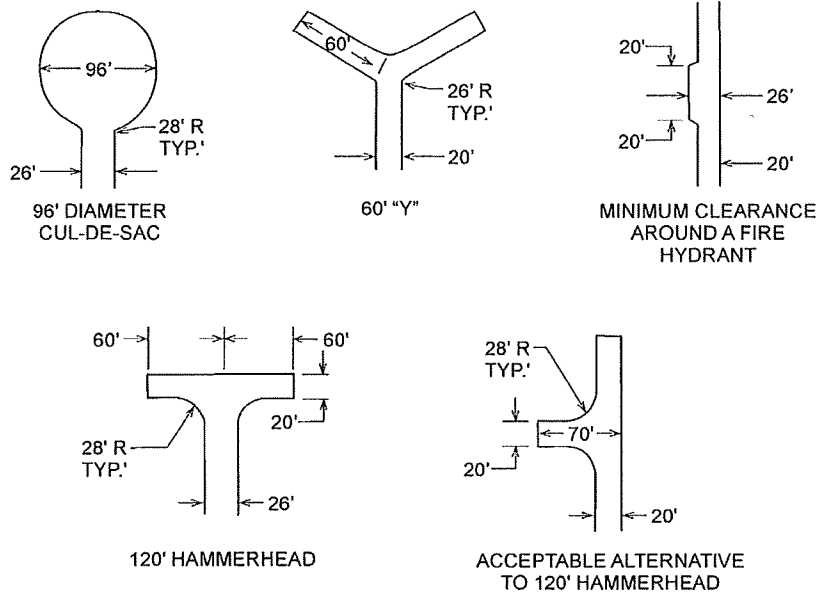

For SI: 1 foot = 304.8 mm.

**FIGURE D103.1  
DEAD-END FIRE APPARATUS ACCESS ROAD TURNAROUND**